

THE LATEST in
MICROWAVE SYNTHESIS
TECHNOLOGY

 Discover[®]



CEM

Microwave-Enhanced Synthesis

THE BEST-SELLING MICROWAVE SYNTHESIS PLATFORM

takes another leap forward with Discover SP. This new system has all of the features for which the Discover series is known, plus an enhanced heating capability, and CEM's new ActiVent Technology, all in one compact simple-to-operate system. As the most advanced technology designed for microwave synthesis, the Discover SP provides superior flexibility with easily interchangeable accessories that enable you to customize a system so you can do your chemistry, your way.

ENERGY EFFICIENT

Why use more power than you really need? Instead of following the conventional approach of applying more power to heat reaction mixtures more rapidly, we improved the cavity of the Discover SP and made it even more efficient. This enhancement gives the Discover SP the best heating cavity using the least amount of microwave power input.

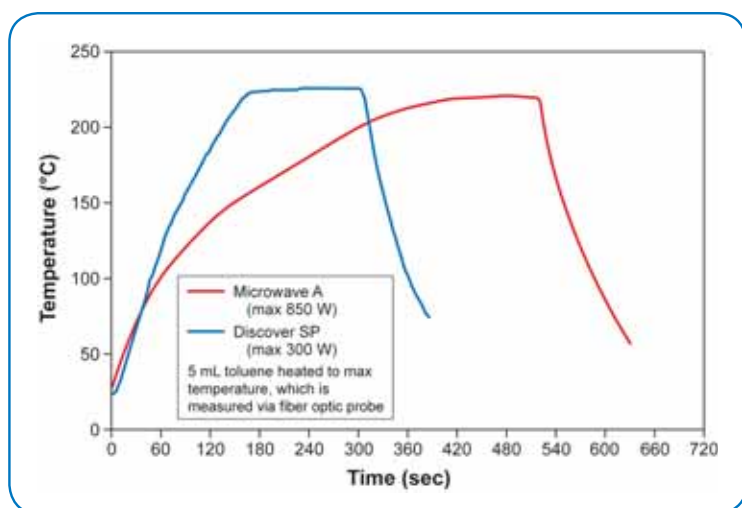

INNOVATIVE ENGINEERING FOR SIMPLE OPERATION

Discover SP is engineered for superior performance. Intuitive software and quick programming make Discover SP the easiest to operate microwave synthesis system you'll ever use.

SUPERIOR DESIGN FOR SIMPLE OPERATION

CEM's patented ActiVent caps for pressure vessels offer a secure seal without the need for crimping tools.

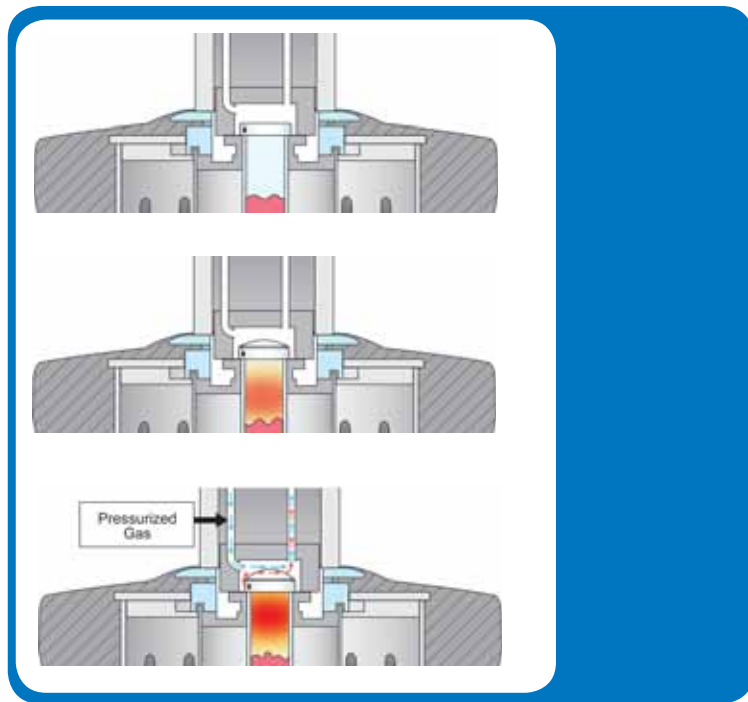

New ActiVent™ Technology

Control your reaction in more ways than ever before.

CEM's patented ActiVent™ Technology is the latest advance in automated pressure control and the safest way to perform pressurized reactions. The ActiVent pressure control system was designed to work exclusively with ActiVent vessels and caps to give you greater flexibility in pressure control and optimum results.

Vent as your reaction progresses or after it is complete

- Perform high temperature/high pressure reactions using either parameter to safely and effectively control the reaction without venting.
- Automatically program the system to release a gaseous byproduct as it forms.
- Ultimate programmability for your reaction. Any material that is released is vented safely through exhaust tubing to a location specified by you.

Vent more effectively during a reaction

- Release unexpected pressure quickly and safely, allowing the reaction to proceed to completion.
- Safely remove unneeded gaseous by-products and help shift the equilibrium of your reaction to generate more product, quickly.
- Perform the reaction in a completely sealed environment.
- Generate a gas in-situ and consume it as a normal reagent. ActiVent safely releases the pressure after the reaction is complete without intervention.

**It's your choice.
Your chemistry, your way.**

DISCOVER SP INNOVATIVE FEATURES

Self-Tuning Cavity

takes all of the guesswork out of ensuring that your reaction is positioned correctly every time, no matter which vessel you use. As the reaction progresses, the microwave energy distribution adjusts automatically for optimum performance and reproducibility.

ActiVent™ Pressure Device

Simple Integrated Attenuator Design

allows full access to the Discover cavity to simplify cleaning process and provide the ultimate flexibility in vessel selection.

Focused Microwave Cavity

is the core of the Discover System. Built around the largest single mode cavity available, the Discover System provides the ultimate flexibility in reaction selection and vessel compatibility.

300-mL Cavity

Discover has the largest single-mode cavity available, providing unprecedented access and vessel flexibility.

Volume Independent IR Temperature Sensor

provides the simplest means to measure the temperature in a reaction in a non-invasive manner. No need for multiple reaction vessels or large minimum volumes with the IR mounted on the bottom.

Electromagnetic Stirring

to ensure maximum agitation for your reaction mixture. Adjust the speed to guarantee your sample mixes each and every time.

Air Cooling for Simultaneous Heating and Reaction Quenching

quickly reduces the overall reaction temperature to quench the reaction upon completion. Air cooling is also the critical component behind PowerMAX™ Technology.

PowerMAX™ Simultaneous Cooling

maximizes the benefits of microwave energy. One of the reasons microwave energy works so well for driving synthetic reactions is because it heats kinetically, not thermally. Localized superheating raises the temperature of the reactant mixture, but energy is actually transferred kinetically. CEM's patented PowerMAX technology uses compressed gas to cool the reactant mixture while simultaneously applying more energy than would normally be used. Reactions proceed much more quickly than normal and do not have time to form side products. This technology is ideal for reactions that require a substantial amount of energy, but may be temperature-sensitive.

Durable Design

An advanced membrane design and specially formulated coating protects parts from solvents and reagents.

Easiest to Clean

Discover SP is designed with a removable spill cup, as well as a drain tray for easy clean up. There's nothing to disassemble, just clean out the cup and the tray and you're ready to run another reaction.

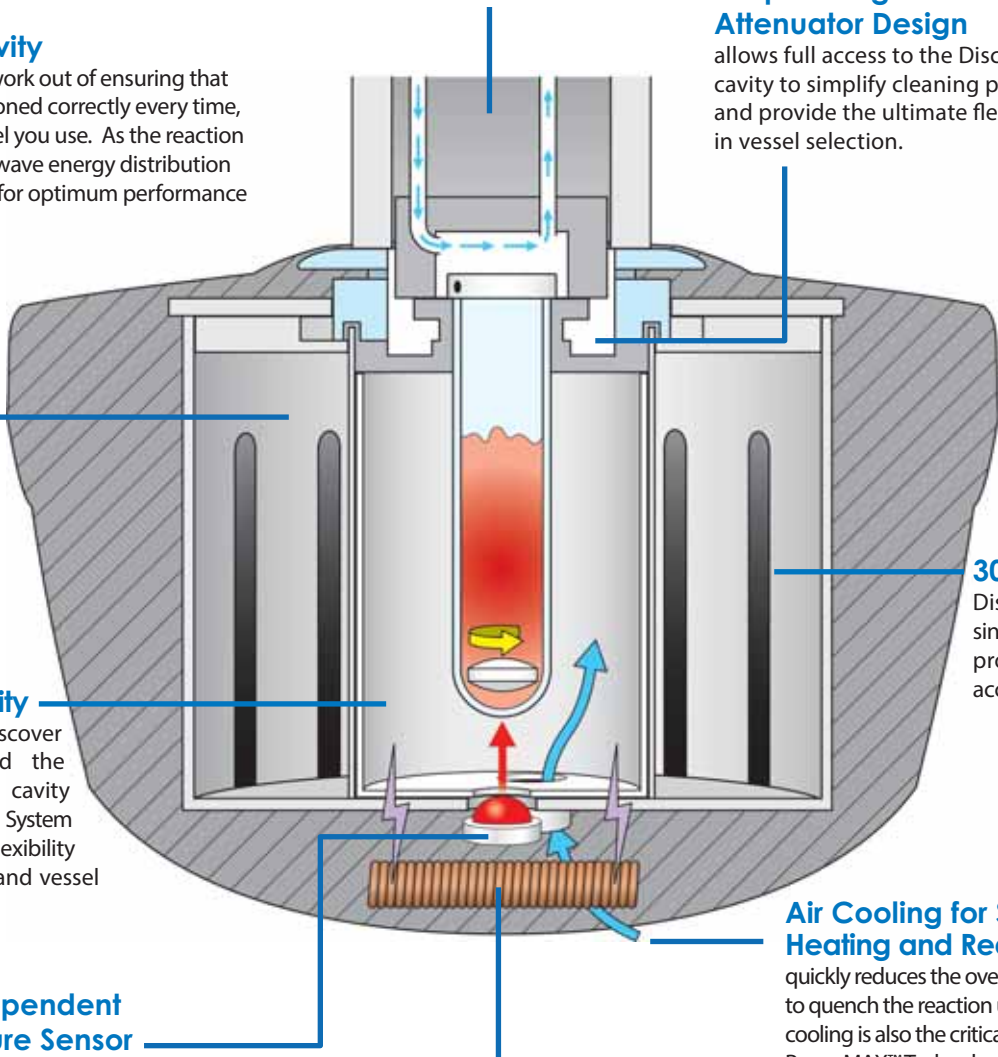

EASIEST-TO-USE VESSELS

YOU CAN'T GET ANY EASIER THAN
CEM'S ActiVent™ CAPS.

NO TOOLS REQUIRED



Perform either **pressurized**
or **non-pressurized** reactions



CoolMate vessel



10-mL flow cell



80-mL vessel

OPEN VESSEL REACTIONS

Discover SP is the only single-mode microwave synthesis system capable of also performing open vessel reactions using standard laboratory glassware and condensers. Discover SP accepts up to a 125-mL round-bottom flask and allows reagent addition and overhead stirring. It can be used with or without a reflux condenser.

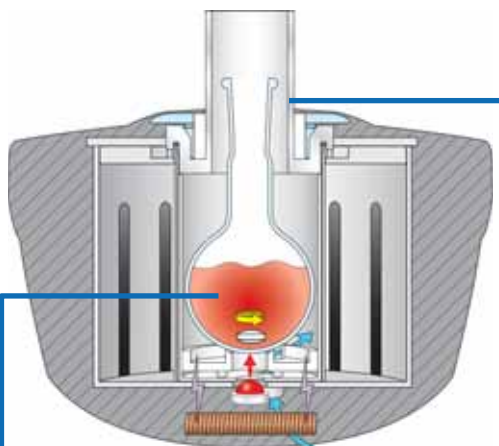

Use round-bottom
flask up to 125-mL

Open Vessel
Attenuator



EXPLORER SP AUTOMATION

Optimize your reactions and expand the capabilities of your laboratory without expanding your lab space. Explorer modules for the Discover SP platform provide fully automated reaction handling capabilities and are an ideal solution to support small groups of chemists as a shared resource.



EXPLORER 12

All of the benefits of a large format autosampler within the footprint of the world's smallest manual reactor. This twelve position autosampler accommodates both the 10- and 35-mL vessels and is the best value of any autosampler commercially available.



Mobile Interface

Run your system and manipulate data with CEM's new flexible, easy-to-use, and powerful Mobile Interface option for the Discover SP Series. The interface can easily be mounted on the Discover to free up benchspace or placed away from the chemicals in the fume hood depending on your needs. Take the interface to your office to analyze data, create new methods, or transfer data into another program. The interface features a large, full color, 10.1" touchscreen, with a mountable dock, which also serves as a charging station. The Mobile Interface also connects wirelessly to Discover Systems running the full version of CEM's Synergy™ software.



Explorer 48, 72, & 96

CEM manufactures autosamplers to accommodate both 10- and 35-mL sealed vessels. Run either size or a combination of both easily. Intelligent rack design allows the autosampler to recognize the vessel type without user input and the integrated robotics ensure that switching between 10-mL and 35-mL reaction vessels occurs seamlessly, freeing your time for other things.

	10-mL Vessels	35-mL Vessels
Explorer 48	Up to 48	Up to 24
Explorer 72	Up to 72	Up to 36
Explorer 96	Up to 96	Up to 48

Mix and match reaction vessel sizes for the ultimate in flexible reaction setup.



ACCESSORIES

Fiber Optic Temperature Control provides the most precise temperature measurement available by directly measuring the temperature inside the reaction vessel. It can be used with 10-mL reaction vessels designed for this purpose, as well as with the 80-mL vessel. Other accessories, including the CoolMate™ and Gas Addition Kit use this type of temperature measurement.

CoolMate™

The CoolMate™ is the only commercially available microwave system designed to perform reactions at sub-ambient temperatures. Reactions such as lithiation, carbohydrate synthesis, and other temperature-sensitive chemistries can now benefit from the use of microwave energy. Use the power of microwave energy to accelerate reactions even at temperatures as low as $-80\text{ }^{\circ}\text{C}$.



Gas Addition

The Gas Addition accessory is the only system specially designed for reactions with gaseous reagents. Perform hydrogenations, carbonylations, or other reactions with gaseous reagents or simply use the vessel to ensure an inert atmosphere during microwave irradiation. This system allows you to purge the reaction vessel and back-fill it with a gas. During the reaction, the gas source is completely shut off from the microwave, thereby ensuring your safety at all times.



Camera

The optional Integrated Camera allows you to see the changes occurring during your reaction. It's the perfect tool for documentation and publication support.

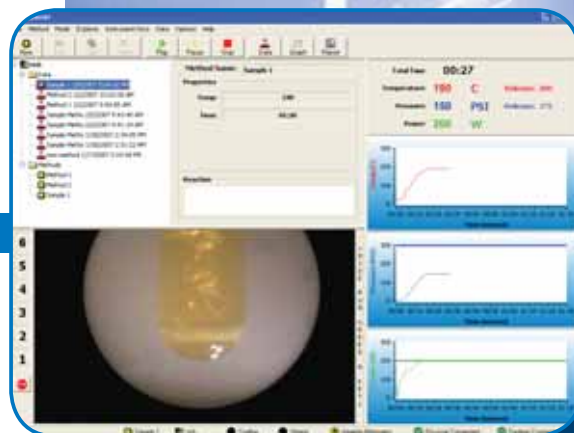

SPECIFICATIONS

HEATING RATE	2-6 °C/second
TEMPERATURE	-80 to 300 °C
PRESSURE	0-30 bar (0-435 psi) ActiVent Self-Venting Technology included for pressure relief during or after reaction
REFLUX REACTION COMPLIANT	Open vessel option included for reflux reactions
POWER	0-300 W
TEMPERATURE MEASUREMENT	Infrared for volume-independent non-invasive temperature measurement Fiber optic probe for direct feedback
OPERATING VOLUME	0.2 – 75 mL 0.2 – 50 mL pressurized
REACTION AGITATION	Electromagnetic stirring with adjustable speeds
AIR COOLING	≥25 psi (20 L/min flow) user-supplied For Simultaneous Cooling (PowerMAX) and reaction quenching
AUTOMATION	12-position [up to 12 (10 mL) vessels or 6 (35 mL) vessels] 48-position [up to 48 (10 mL) vessels or 24 (35 mL) vessels] 72-position [up to 72 (10 mL) vessels or 36 (35 mL) vessels] 96-position [up to 96 (10 mL) vessels or 48 (35 mL) vessels]
AVAILABLE ACCESSORIES	Mobile Interface Camera Sub-ambient reactions (CoolMate Sub-Ambient Microwave System) Gas Addition kit Flow Cell Peptide Synthesis Enzymatic Digest
WEIGHT	38 lbs. (17.3 kg)
DIMENSIONS	14.2"W x 16.9"D x 11.2"H (36.1 cm x 42.9 cm x 28.4 cm)

CEM Corporation

World Headquarters

PO Box 200
Matthews, NC 28106
Tel: 800-726-3331
Tel: 704-821-7015
Fax: 704-821-7894
Email: info@cem.com
www.cem.com

SUBSIDIARIES

United Kingdom

CEM Microwave Technology Ltd.
2 Middle Slade
Buckingham Industrial Estate
Buckingham MK181WA
Tel: (44) 1280-822873
Fax: (44) 1280-822873
Email: info.uk@cem.com
www.cemmicrowave.co.uk

Germany

CEM GmbH
Carl-Friedrich-Gauss-Str.9
47475 Kamp-Lintfort
Tel: (49) 2842-9644-0
Fax: (49) 2842-9644-11
Email: info@cem.de
www.cem.de

Italy

CEM S.R.L.
Via Dell' Artigianato, 6/8
24055 Cologno al Serio (Bg)
Tel: (39) 35-896224
Fax: (39) 35-891661
Email: info.srl@cem.com
www.cemmicroonde.com

France

CEM µWave S.A.S.
Immeuble Ariane
Domaine Technologique de Saclay
4, rue Rene' Razel
91892 ORSAY Cedex
Tel: +33 (01) 69 35 57 80
Fax: +33 (01) 60 19 64 91
Email: info.fr@cem.com
www.cemfrance.fr

Japan

CEM Japan K.K.
2-18-10 Takanawa
Minato-ku, Tokyo
108-0074
Tel: +81-3-5793-8542
Fax: +81-3-5793-8543
Email: info@cemjapan.jp
www.cemjapan.jp

Ireland

CEM Technology (Ireland) Ltd.
Sky Business Centre
9a Plato Business Park
Damastown
Dublin 15
Tel: +353 (0) 1 885 1752
Fax: +353 (0) 1 885 1601
Email: info.ireland@cem.com
www.cemmicrowave.co.uk

